

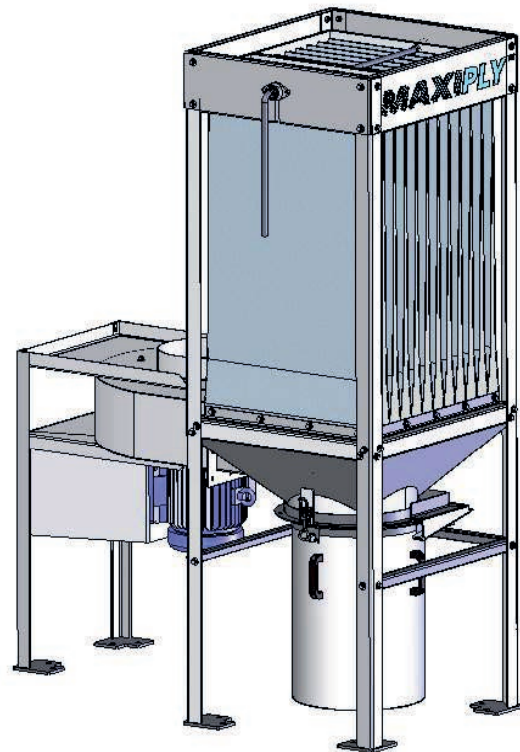

**DUST COLLECTION
& SOURCE CAPTURE**

Owner's manual for installation,
use and maintenance



MAXIPLY™

**OPEN TYPE DUST COLLECTOR
DMP-170, DMP-170S, DMP-270, DMP-270S,
DMP-350, DMP-350S, DMP-450 & DMP-450S**

This manual is property of the owner. Leave with the unit when set-up and start-up are complete.
AQC Dust Collecting Systems inc. reserves the right to change design and specifications without prior notice.

INDEX

1	Introduction	3
2	Information on the dust collector	3
3	Presentation	4
3.1	Each MAXIPLY unit includes	5
4	Normal use	5
5	Functioning	6
5.1	Cleaning of the filter envelope	6
5.2	Manual shaker (optional)	6
6	Installation	6
6.1	Inspection of the material	6
6.2	Area of installation	6
7	Assembly	7
7.1	Necessary tools	7
7.2	Installation and assembly	8
7	Electrical connections	12
7.3	Ducting systems	13
8	Start-up	13
8.1	Check list	13
8.2	Shaker system	13
8.3	Electrical connections	13
9	Start/Stop procedure	14
9.1	Starting the unit with a new filter envelope	14
9.2	Normal start-up	14
9.3	Shutting the unit OFF	14
10	Safety measures	14
10.1	Workers/Staff	14
10.2	Electrical components	15
10.3	Anchor	15
10.4	Processes creating spark	15
11	Maintenance	15
11.1	Replacing the filter envelope	15
11.2	Remplacement of the filter enveloppe	16
12	Maintenance and inspection	16
13	Troubleshooting	17
14	Warranty	19
15	Limitation of liability	20
16	Applicability	20
17	Governing law	20

1 INTRODUCTION

This manual refers to the MAXIPLY dust collector and its shaker cleaning system. It includes important information on the installation, function and maintenance of your dust collector. You must read this manual thoroughly and apply all directives. You must also inform the personnel using the dust collector about the safety measures and maintenance instructions.



WARNING!

5000 CFM (2.36 m³/s) maximum our handling. MAXIPLY dust collector are of the open type for unside installation. It is not to be used on sanders, wolders or abrasive planers having mechanical feed systems. Collected dust should be removed daily. Open type collectors such has MAXIPLY do not require spark suppression systems or no-return valves are not required as per NFPA 664. Contact A.Q.C. Inc. if you have any doubt as to the use of your dust collector. **Not following directives and procedures could cause injuries or property damages.**

2 INFORMATION ON THE DUST COLLECTOR

Model: _____ Serial number: _____

Delivery date: _____ Date of installation: _____

Name of customer: _____

Address: _____

Accessories: _____

Other: _____

3 PRESENTATION

The MAXIPLY unit is an open type dust collector with an envelope type filter. It is mostly designed for industrial use, educational or for applications requiring 5000 CFM or less.

The MAXIPLY unit is equipped with a manual shaker system which cleans the entire filter surface without the use of compressed air or electrical motor.

The MAXIPLY unit may have between 170 to 700 sq. ft of filter depending on the model selected.

Figure 1

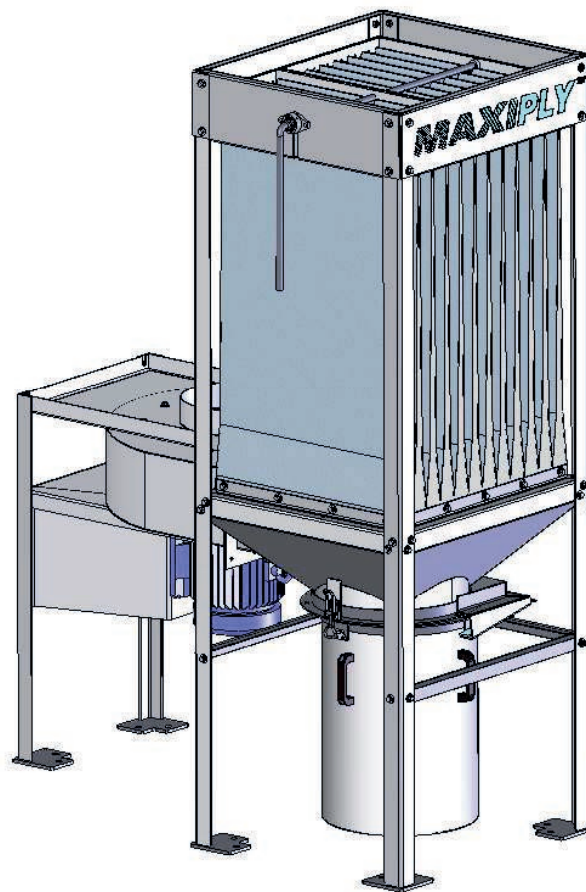

PRESENTATION DMP-170S

3.1 Each MAXIPLY unit includes:

- Welded steel hopper.
- 25 gallon dust bin.
- Quick-clip dust bin removal system.
- 1 polyester filter envelope having between 170 to 700 sq. ft of filter surface. Maximum air to cloth ratio to be 10:1.
- Various hardware.
- Handle for filter shaker cleaning action.
- Aluminum direct drive radial type fan/motor assembly.
- 3 step paint preparation: degreasing, primer and polyurethane base paint final coat.

The MAXIPLY unit is shipped partly assembled and some components will require field assembly. This will allow the dust collector to be assembled in an area where the access doors are narrow where fully assembled unit would not fit through the doorway frame. The electrical connection of the fan motor must be performed by a qualified electrician.

4 NORMAL USE AS PER NFPA 664

The MAXIPLY unit is designed to filter harmful dusts from the air resulting from a fabrication process. Each MAXIPLY dust collector is built based on the request and information supplied by the customer for a given application and should not be used for any other application unless approved by A.Q.C., Inc. The dust collector should be used at intervals in order for the filter envelope to be cleaned at the end of each cycle of use.

5 OPERATION

During normal use, the MAXIPLY unit receives dust filled air from the blower toward the collector inlet. The smaller particles are pushed toward the filter envelope and the larger particles fall into the dust storage compartment. The smaller particles are stored into the filter envelope and clean air is exhausted through the four (4) opened sides of the filter cabinet.

5.1 Cleaning of the filter envelope

When the collector is shut down, the operator must wait until the motor has stopped turning completely. The cleaning is made by shaking by hand the pockets of the filter bag.

5.2 Manual shaker (optional)

When the collector is shut down, the operator must wait until the motor has stopped turning completely. The cleaning is made by vigorously shaking the handle on the side of the unit.

6 INSTALLATION

6.1 Inspection of the material

The MAXIPLY unit is shipped on one (1) or multiple skids. Proceed with a visual inspection upon receiving the material for any damages or missing skid(s). **Note:** if damages are apparent upon receiving the material, indicate so on receiving slip (freight waybill) and confirm by having the truck driver sign the waybill with any discrepancy. A.Q.C takes photos of material prior to shipping. Generally, shipment includes a skid for the collector cabinet and another one for the dust storage system. Other optional devices are shipped on separate skids.

6.2 Area of installation

1. The area chosen to install the collector should be able to support its weight, its accessories, dust storage system and ventilation ducting. The construction of a solid flat surface such as a concrete pad may be needed.
2. Position the dust collector in a way to have access to the blower and filter envelope. A 12" (0,3 meter) work space is required around the collector for maintenance purposes.

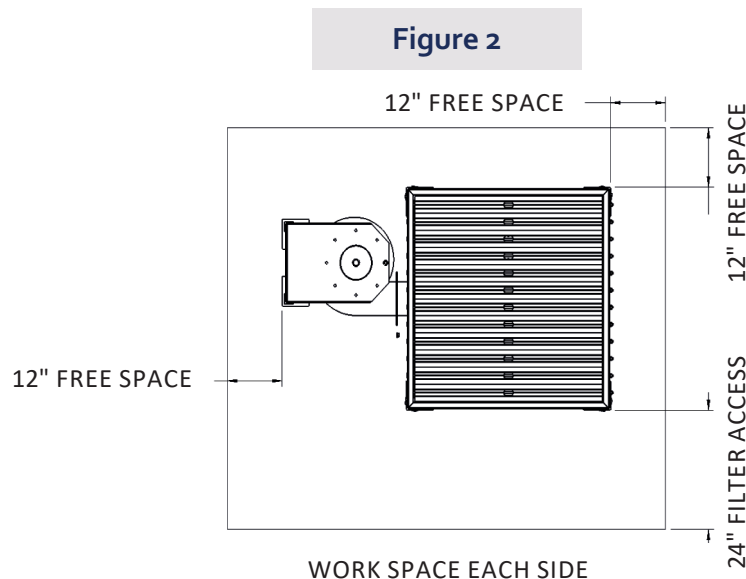
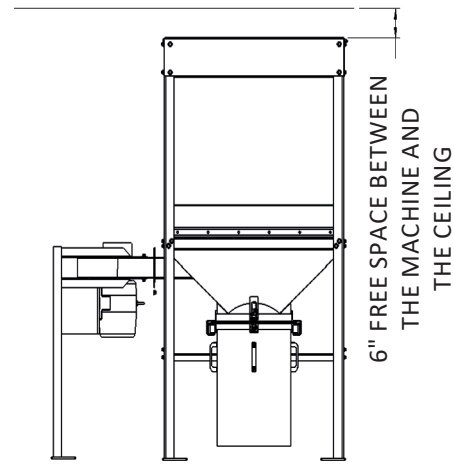

Figure 3



WORK SPACE ABOVE COLLECTOR

Follow rules and regulations regarding an open type dust collector installed within a facility. Generally, such collector should comply with the following requirements if it is to be used for collecting combustible dusts:

1. Must not be connected to a planer or sander with mechanical feed.
2. Must be installed 20' (6 meters) or more away from any work station, walkway or emergency exit. If needed, a proper protective wall against blasts must be installed.

7 ASSEMBLY

7.1 Necessary tools

The following tools and equipment are recommended for the assembly of the dust collector :

- Crane or fork lift
- Swing jib
- Chains
- Shackles
- Eye bolts
- Tapered steel pins
- Ratchet set
- Spanners and/or wrenches
- Power drill
- Concrete drill bits
- Concrete anchors
- Nuts, washers and bolts
- Self tapping crews
- Silicone tubes

7.2 Installation and assembly

1. Prepare the area where the dust collector is to be installed and should be free of obstacles
2. Assemble the support legs on dust hopper and in sequence as shown. **Leg # 1** is installed front left, **leg # 2** front right and **legs # 3 and 4** are at the back of the unit. Attach the assembly with the fasteners supplied.

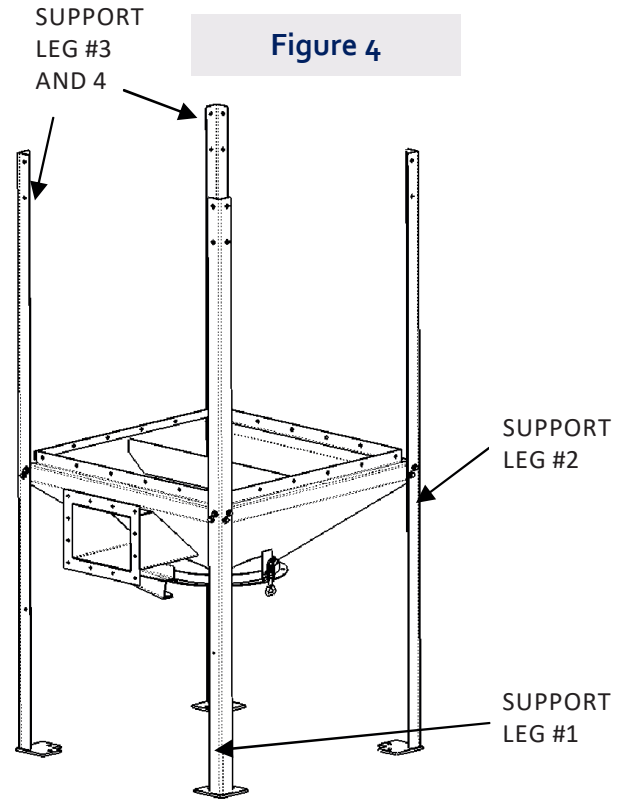

ASSEMBLY STEP 2

3. Install the cross braces (3 pieces # 4) on the bottom section of the support legs. Use the fasteners supplied.

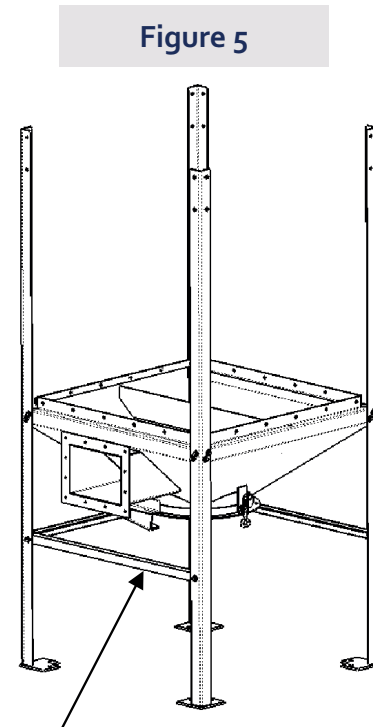

CROSS BRACES #4

ASSEMBLY STEP 3

- Referring to figure 6, install top panels # 5 and 6. The panels with holes must be facing the dust collector inlet.

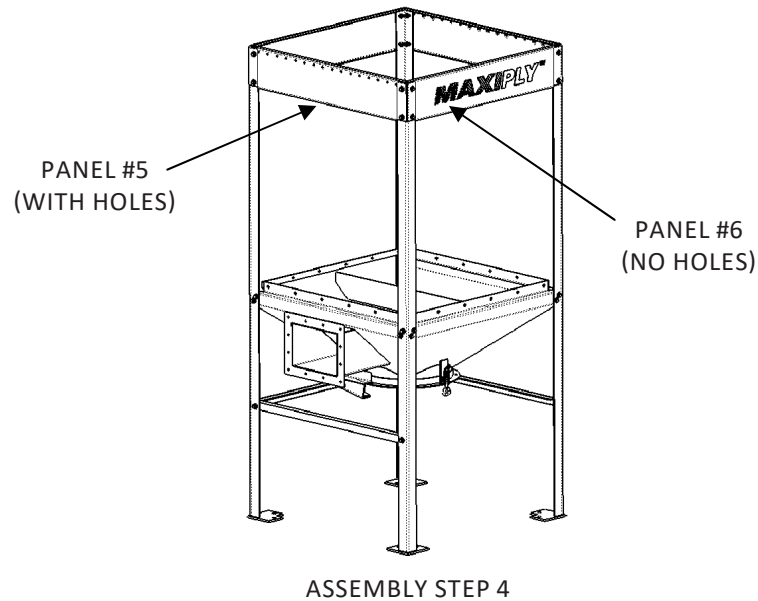

- The bottom part of the filter envelope is bolted to the filter frame section of the hopper. This is to ensure the filter envelope is not damaged during freight. at the factory. The upper part of the filter needs to be attached to the part of the dust collector frame. In order to do so, insert the rods through the filter sleeves in both # 5 panels. Tighten with the fasteners (supplied). For the installation of the optional manual shaker system, refer to the installation section of this device (page 10).

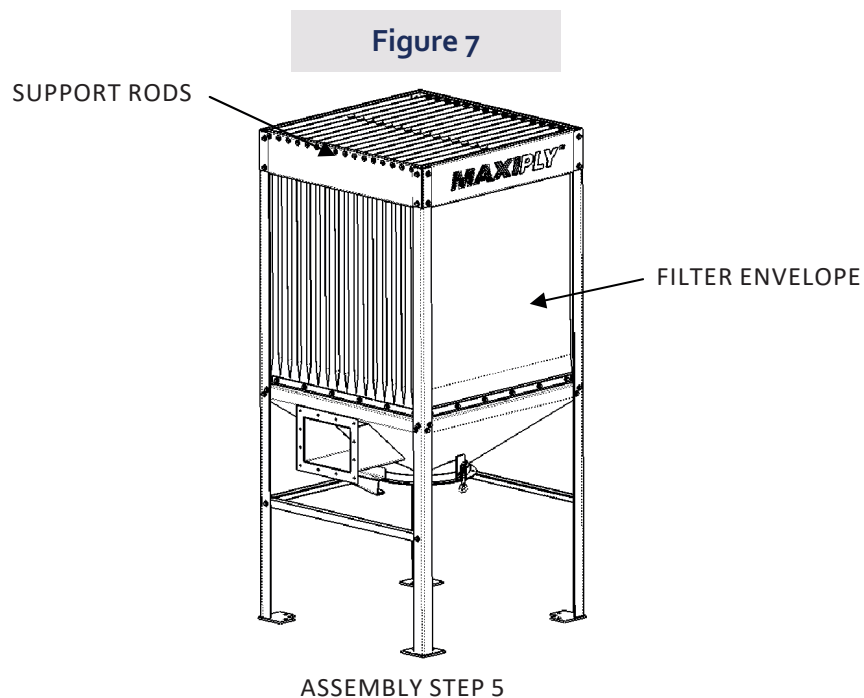

6. Install the dust storage bin by inserting it into the guides underneath the hopper. Once this is done, lift the bin and clip it in place.

Figure 8

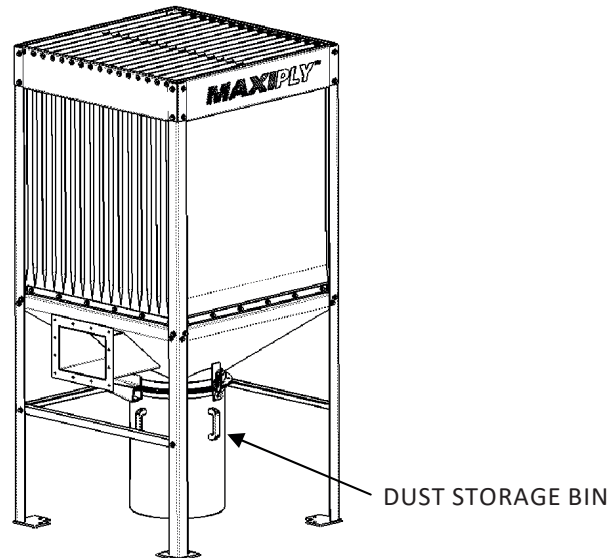

ASSEMBLY STEP 6

7. Lift the fan assembly in a way that the motor is facing toward the floor and the outlet of the fan facing the inlet of the collector. Install the fan support legs at the back of the fan assembly. Align the fan assembly with the collector inlet. Fasten the fan outlet and collector inlet together with the fasteners supplied.

**WARNING!**

The use of a swing jib is recommended in order to avoid damages to the collector cabinet.

Figure 9

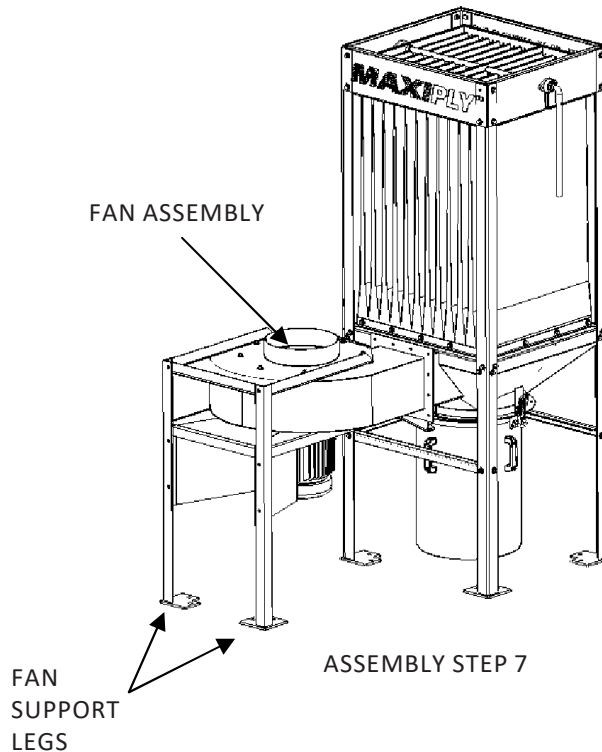

8. Install a grounding wire.
9. Install anchor bolts to secure the collector to the floor. (floor anchor bolts are not supplied)
10. Final step is to connect the main ductwork to the fan inlet (top). Filter assembly with shaker.

**WARNING!**

Steps 1 through 5 mentioned above must be performed prior to installing the filter shaker frame.

1. Install the filter shaker frame by lifting it and by inserting the shaker handle through the opening in the upper filter frame. Attach the filter frame to the upper panels with the fasteners (supplied).

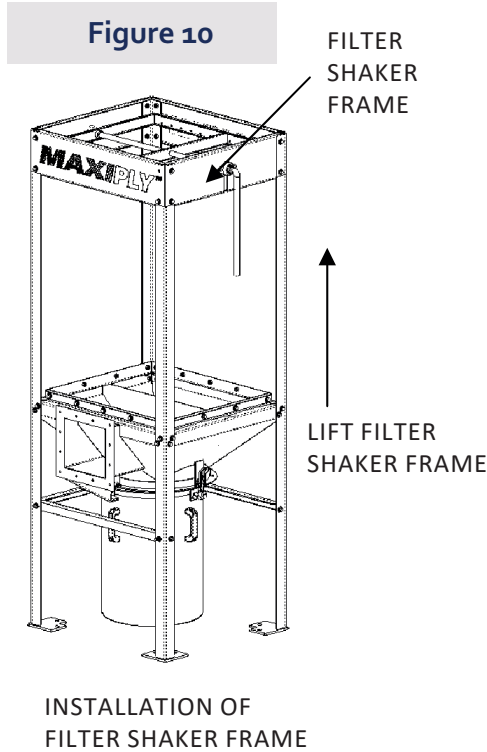

2. Insert the rubber bands through the bows and attach them to the filter shaker frame. Refer to drawing below.

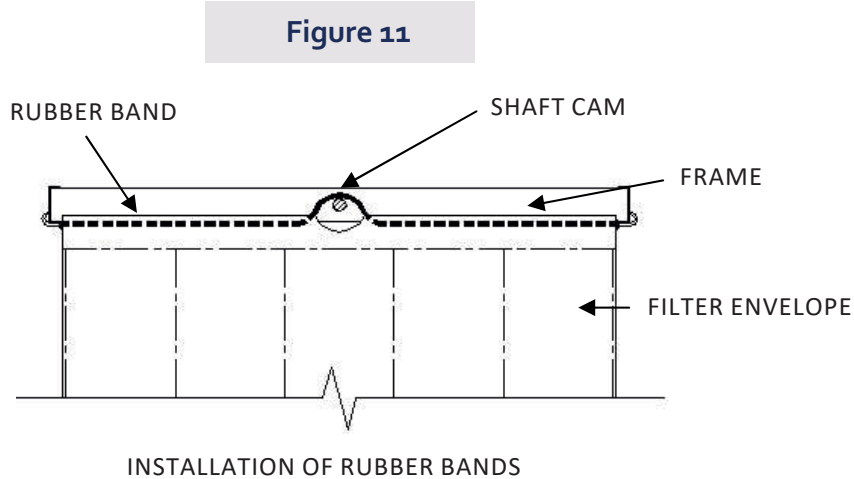

7 ELECTRICAL CONNECTIONS



WARNING!

The electrical connection must be performed by a certified electrician and by applying local building rules and regulations. For safety measure, disconnect all electrical power prior to installation.

The fan starter is not supplied by A.Q.C. Inc. Contact A.Q.C. Inc. for information on the proper starter for your dust collector.

The electrical panel may be installed directly on the MaxiPLY unit or remote.

Once all electrical connections have been completed, switch **"ON"** the motor and check for proper blower wheel rotation.

7.3 Ducting systems

- The dust collector should be installed as close as possible to the machines creating the dust. This is to minimize the length of the ductwork.
- If possible, do not install short radius elbows or bends.
- Install taps or branches having a 30 degree slope or less.
- Do not install straight 90 degree taps (T's).
- Join ductwork and branches using self tapping screws and silicone. Preferred ducting system is clamp-on type not requiring any screws causing possible jams and dust build-up at the screws.

8 START-UP

8.1 Check list

Before starting the dust collector for the first time, the steps listed below should be followed to ensure the collector will work properly.

- Remove all objects in the vicinity of the collector inlet and outlet.
- Ensure all accessories and optional equipment are secured and installed correctly.

8.2 Shaker system

- Check if the upper filter frame is well in place and fastened correctly.

8.3 Electrical connections



WARNING!

The electrical connection must be performed by a certified electrician and by applying local building rules and regulations. For safety measure, disconnect all electrical power prior to installation.

- Check if all electrical connections are watertight and proper electrical current is available.
- Check if all remote controls (if supplied) are connected to the control panel and all switches are at the **"OFF"** position.
- Supply power to the collector.
- Start the fan and shut it **"OFF"** immediately. Check motor rotation.

9 START/STOP PROCEDURE

9.1 Starting the unit with a new filter envelope

Shut inlet and outlet dampers (if installed) at about 50% before starting the unit. Allow a few hours for dust to penetrate the filter envelope before starting the shaker system. This will result in a better filtration efficiency and longer filter envelope lifetime.

9.2 Normal start-up

Start the collector and allow dust to enter the unit.

9.3 Shutting the unit OFF

Shut down power to the collector and close all inlet and outlet dampers so that dust does not flow back into the unit. You may now access the collector for inspection, drum change or drum empty out and/or filter envelope replacement.

10 SAFETY MEASURES

10.1 Workers/Staff

Any maintenance on the collector should be accomplished by a minimum of two (2) workers. When finished, retrieve all tools inside the collector.

All maintenance staff should wear protective clothing or apparatus such as goggles, gloves, breathing equipment or such devices before working inside the collector.



WARNING!

Never perform maintenance tasks by an unaccompanied worker. All personnel must be accounted for before restarting the collector.

10.2 Electrical components

To avoid injuries, all electrical components must be shut off prior to inspection or servicing the unit. This procedure includes getting access to the filter section.

10.3 Anchor

All sections of the collector should be firmly anchored to the floor in order to prevent tipping of the unit should an explosion occur or by accidentally hitting the unit with moving equipment such as lift trucks.

10.4 Processes creating spark

This dust collector is designed for wood dust only.

11 MAINTENANCE



WARNING!

Refer to the safety measures section before proceeding with the inspection or maintenance of the dust collector.

A scheduled preventive maintenance program will reduce downtime situations and increase lifetime of the unit. Charts shown in this chapter refer to maintenance and procedures related in solving malfunction. Timers and delays may be modified with conclusive experimenting of the system on a particular application.

11.1 Replacing the filter envelope

The lifetime of the filter envelope is directly linked to its resistance to the dust filtered and does not necessarily require a regular filter replacement. However, if the filter envelope is torn or punctured, it needs to be replaced as soon as possible.

11.2 Replacement of the filter envelope

1. Unfasten the attachment bars at the bottom of the filter envelope located on all four (4) sides of the collector.
2. Remove the upper filter envelope support rods (rubber bands for optional manual shaker system)
3. Remove the filter envelope from the lower frame.
4. Position the new filter envelope on the frame and reinsert the support rods. Ensure the fasteners are tightened and the filter envelope is well in place.
5. Reinstall the attachment bars or rubber bands for the optional manual shaker system.

12 MAINTENANCE AND INSPECTION

The chart indicated below shows different inspections and the frequency at which they should be performed.

Frequency of inspections	Components	Procedures
Daily	Dust collector	Check for dust leaks around the air inlet and the filter envelope frame. Refer to Troubleshooting on page 17 of this manual.
		Check dust level in dust storage bin. Empty.
Weekly	Filter envelope	Check for leaks on the filter envelope. Repair or replace if necessary. Ensure the filter envelope is securely fastened.
Semi-annually/Annually	Dust collector	Examine, clean and apply paint touch-ups if necessary. If needed, lubricate the shaker and shaft rocking system using lithium base grease.

13 TROUBLESHOOTING

Problem	Probable cause	Solution
Smoke or dust escaping from the filter or around the filter frame	Filter envelope not installed properly	Tighten fasteners on filter frame to ensure proper seal.
	Leak in filter envelope	Repair or replace filter envelope.
	Damaged seal	Repair or replace seal.
Drop in filter efficiency	High level of humidity within the collector	Check humidity level or relative humidity within the collector. A slightly higher humidity level may be corrected by closing some gates and by shaking the filter. If the humidity level is too high, take necessary measures to dry the the air before it enters the collector.
	Air volume too low or too high	Check for speed and motor rotation and the position of gates. Make necessary adjustments to obtain original specifications.
	Filter envelope not suited for dust to be filtered	Replace filter envelope with a filtration system suited for the dust to be filtered.
	Filtered air temperature is higher than normal	Check temperature of air to be filtered. Bring necessary adjustments to obtain satisfactory temperature.
	Static electricity build up in dust collector	Check for appropriate grounding wires of collector, components and ducting system. Increase relative humidity of air to be filtered if lower than 50% R.H. until the dust to be filtered is affected.

Problem	Probable cause	Solution
Air volume is less than original design	Air leaks in the system	Check for leaks in the ducting and connections. Seal leaks.
	Ducting and / or filter envelope obstructed	Check filter envelope for clogs, debris, etc. Check for clogs in ducting system and gates. Repair, clean or modify if necessary.
Rapid deterioration of filter envelope	Temperature is higher than normal in collector	Check filtered air temperature. Bring necessary corrections to obtain proper temperatures.
	Dust filtered is not compatible with filter envelope	Check for dust properties to be filtered. A.Q.C. Inc representative or consultant will guide you for compatible filter. Replace if necessary.
	Presence of humidity in filtered air	Reduce or modify humidity factor. Replace filter envelope.
	Clog in hopper section	Find the clog and clean hopper.
	Incorrect installation of filter envelope	Examine the filter envelope and locate damages caused by a faulty installation. Repair or replace filter envelope if necessary.
	Abrasion of filter envelope due to high inlet velocity	Examine the filter envelope for holes or punctures. If needed, install a diffuser at air inlet.

14 WARRANTY

- 14.1 **Coverage:** Aireau Quality Control Inc. or its designated affiliate (the "Seller") selling the product (the "Product"), warrants that the Product sold by Seller will be free from defects in material and workmanship for a period of 12 months from the date of its installation or 14 months from the date of shipment by Seller, whichever date is earlier (the "Warranty Period").
- 14.2 **Exceptions:** This warranty does not apply to any Product or portion thereof that: (i) has been used in a manner not in compliance with Seller's or manufacturer's documentation and instructions, (ii) has had changes, alterations or repairs made by a person other than a person authorized by Seller, (iii) has been improperly installed or used or has been installed or used contrary to applicable codes, standards, laws and regulations, (iv) has been subjected to improper storage, accident, neglect, misuse or abuse, (v) has been damaged during shipping, (vi) has been subject to damages resulting from normal wear and tear, (vii) has not been used with appropriate fire protection systems or explosion venting when required or (viii) has not been installed by a licensed contractor with experience in fire and explosion hazards and applicable codes, laws and regulations. For greater certainty, this warranty does not apply to filters sold as part of, or for use with, the Product. Unless specifically accepted otherwise in writing by Seller, Seller does not warrant that electrical equipment will comply with any laws or regulations of the customer's jurisdiction.
- 14.3 **Claims:** To benefit from this warranty, customer must notify Seller in writing of the Product defect, which notice shall include a reasonable description of the defect, within 10 days from the date such defect is discovered or ought to have been discovered.
- 14.4 **Remedy:** During the Warranty Period and subject to the terms herein, Seller will, at its option, either: (i) repair or replace the Product or any defective parts or components (except for filters) with Product, parts or components (except filters) free from defect or (ii) credit or refund the purchase price of the Product. If Seller so requests, customer must return the defective Product to Seller's place of business determined by Seller. Shipping, installation, removal and re-installation costs will be solely borne by the customer. **The foregoing shall be customer's sole and exclusive remedy for any defect in the product, its parts and components and for any breach of the warranty herein.**
- 14.5 **Disclaimer:** Except as set forth in this section 1, each of seller, its affiliates and their directors, officers, subcontractors and representatives (the "seller parties") disclaims all representations and warranties, whether written, oral, express, implied, statutory, or otherwise, including all implied warranties of merchantability, quality, fitness for a particular purpose, non-infringement, and warranties arising from a course of dealing, course of performance, usage, or trade practice and customer hereby expressly waives any right related thereto. Without limitation to the foregoing and except as expressly set out herein, the seller parties do not represent or warrant that: (a) the use of the product will be timely, uninterrupted or operate in combination with any other hardware, software, system or data or (b) the product will meet customer's intended use, requirements or expectations.

15 LIMITATION OF LIABILITY

- 15.1 **Limitation of Liability:** Notwithstanding anything to the contrary, in no event will the seller parties' liability arising out of, or related to, the product or its parts and components, whether pursuant to contractual or extracontractual liability, tort or under any other theory of liability, exceed the price paid to seller for the product giving rise to such liability.
- 15.2 **Exclusion of Consequential and Similar Damages:** Notwithstanding anything to the contrary, in no event will the seller parties be liable for any indirect, punitive, special, exemplary, incidental, consequential or other similar damages of any type or kind (including loss of revenue, profits, use or other economic advantage, damages due to product failure, work stoppage or delays in delivery) arising out of, or in any way connected to, the product or its use, breach of contract, tort (including negligence), strict liability, product liability, or otherwise, regardless of cause, even if the seller parties had previously been advised of the possibility of such damages or could have reasonably foreseen them.
- 15.3 **Fire and Explosion and Acceptance of Risk:** Customer acknowledges that improper installation or use of the Product may result in fire or explosion. To minimize such risks, proper installation, operation, and maintenance of the Product in accordance with all applicable codes, standards, laws and regulations is critical. Prior to installation and use, customer shall ensure that the Product meets the applicable codes, laws and regulations, including those related to the addition of appropriate fire protection systems or explosion venting. Installation shall be performed by a licensed contractor with experience in fire and explosion and applicable codes, laws and regulations.

16 APPLICABILITY

- 16.1 The terms herein constitute the only warranty given by Seller with respect to the Product. No other terms and conditions, whether included on a purchase order or in any other document, shall apply or bind the Seller with respect to the Product warranty and all such terms and conditions and documents are expressly disclaimed.

17 GOVERNING LAW

- 17.1 These warranty terms will be governed by and construed under the laws in force in the Province of Ontario, Canada, excluding its conflict of law rules.